

## REFUELING

Ø 32 mm

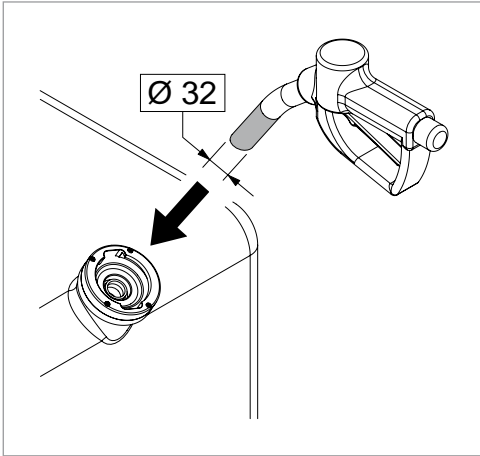

Ø 25 mm

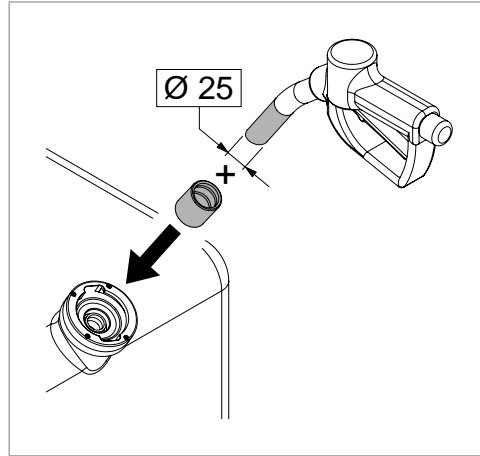

# KOCKÓN MACH II

## - THREAD TYPES -

### INSTALLATION

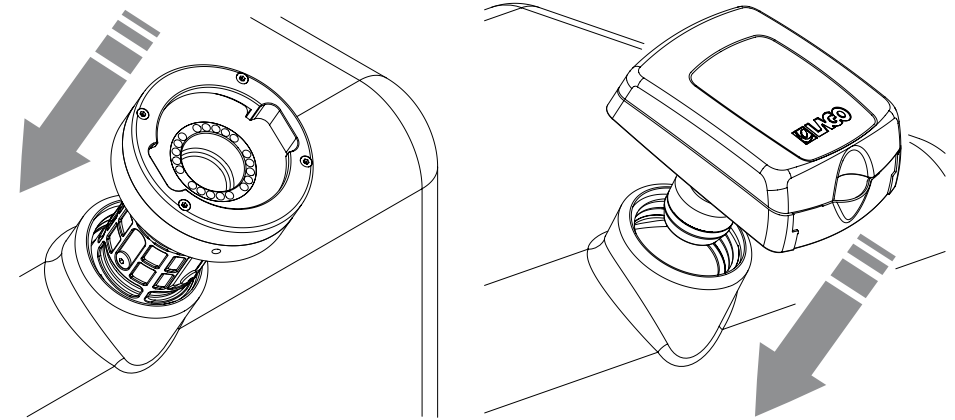

AVVERTENZE / WARNINGS / WARNUNGEN / AVERTISSEMENTS / ADVERTENCIAS  
AVISO / VAROVÁNÍ / UPOZORENJA / FIGYELMEZTETÉS / UWAGA / INSTRUCȚIUNI  
VAROVANIA

- (IT) Rispettare gli allineamenti, le misure e gli orientamenti riportati in figura.
- (UK) Please respect the alignments, the measures and orientations shown in the illustrations.
- (DE) Ausrichtungen und die MaßnahmenwieimBild.
- (FR) Respecter les alignements, les mesures et les orientations reportéesen illustration.
- (ES) Respetar las alineaciones, las medidas y las orientacionestraídasenfigura.
- (PT) Observe osalinhamentos, as medidas e as orientaçoēsapresentadasnaFigura.
- (CZ) Dodržujte rozestavení, rozměry a nasměrování uvedené na obrázcích.
- (HR) Pridržavati se poravnanja, mjera i smjerova prikazanih na slici.
- (HU) Tartsa be az ábrákon szereplő beállításokat, méreteket és iránymutatásokat!
- (PL) Przestrzegać ustawień, miar oraz orientacji wskazanych na rysunkach.
- (RO) Se vorrespectaalinierele, dimensiunileșiorientărilefolositeîn figuri
- (SK) Dodržujte rozostavanie, rozmery a nasmerovania uvedené na obrázkoch.

# CAP / UNICAP / PL CAP

**1**



ULTIMATE/SB ≥ 250 mm  
XL ≥ 140 mm



**2**

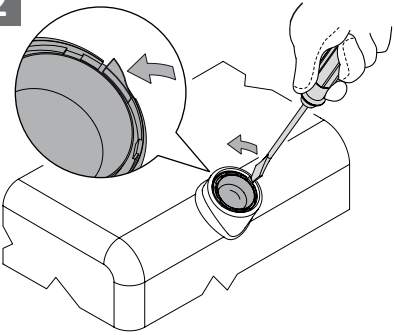

**3**

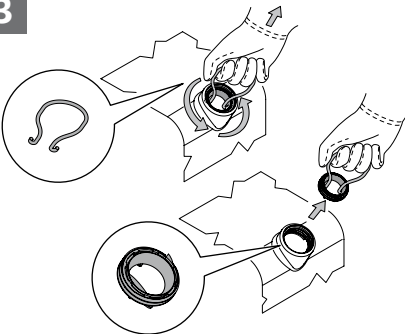

ULTIMATE      SB      XL



**4**

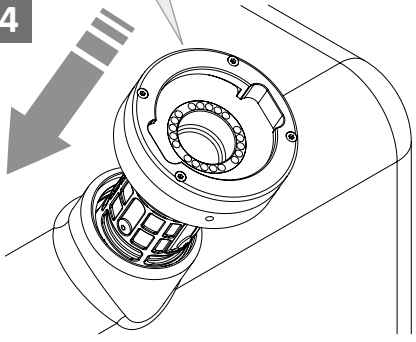

OPTIONAL

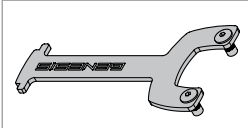



# ZIP / ZIPPER

**1**



ULTIMATE/SB ≥ 250 mm  
XL ≥ 140 mm



**2**

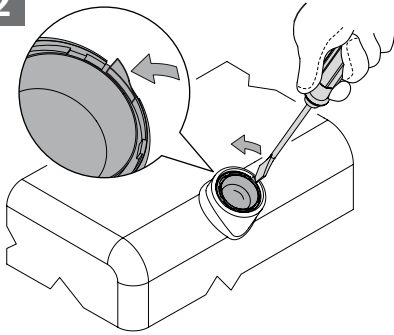

**3**

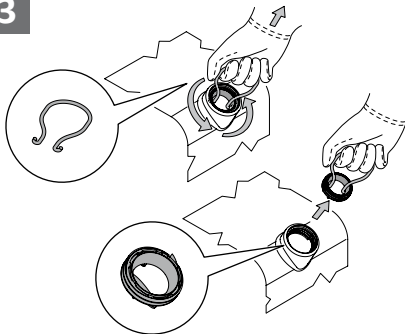

ULTIMATE      SB      XL

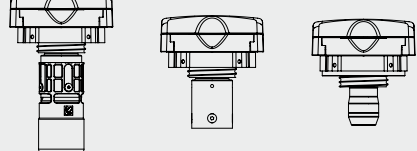

**4**

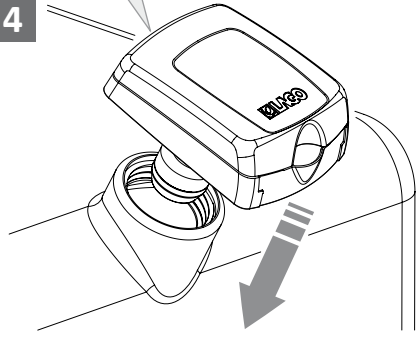

OPTIONAL

